



PropSava[®]

Single Phase Power Optimisation System

User Manual



Single Phase 230V Units
5KVA, 12KVA, 18KVA, 23KVA,
30KVA, 40KVA & 60KVA

Customer Support Contact

Email: customersupport@vanguardspower.com

Website: <http://www.vanguardspower.com>

Contents

Thank you:	01
Product Package Contents:	01
Safety Information:	01
Installation:	03
Wiring Diagrams:	04
Power On Test:	04
Normal Power On:	05
Service and Maintenance:	05
Working Principle:	05
Display Panel:	06
Specifications:	07
Surge Protection System:.....	08
Fault Finding and Recommendations :.....	09
Declaration of Conformity:	10
Warranty Terms & Conditions:	11
Warranty Card:	12

Thank you:

Thank you for purchasing the PropSava® Single Phase, Power Optimisation System. We believe it will provide you with many years of service and significant electric power savings.

Please read the following safety instructions and keep this User Manual available so that you can refer back to it at any time.

Product Package Contents:

- A) 1 x PropSava - 1 x Available in various KVA sizes. Please see the rear of the unit for the Manufacturers Plate for specific information on power and voltage settings.
- B) 4 x Terminal cable eyes fixed on connector block at rear.
- C) 1 x User Manual
- D) 10 x Spare fuses

Safety Information:

WARNING:

The PropSava MUST be installed by a qualified Electrician who holds nationally recognised qualifications for the installation of electrical high amperage mains equipment. Failure to use a qualified and competent installer can result in fatal injuries. Be sure to turn off the power before installing or servicing any PropSava. Fire can result from loose electrical connections. Ensure that all connections are secure. Local and National codes of installation and safety must be adhered to for the installation of the PropSava. If you do not know or are not familiar with local and/or national codes for the installation of high amperage mains equipment, please contact your local authority building inspector department for advice and/or guidance.

1. Please check that the voltage and power rating of the PropSava matches the voltage and plus 20% load of the property. The information as to the voltage and load of the PropSava can be found on the rear casing on the Manufacturers Plate. There should always be 20% more load ability in the PropSava than the maximum requirement of the property; and at least equal to the maximum loading of the mains power breaker switch of the Fuse/Consumer Board.

2. Check the PropSava for any obvious signs of damage from transportation. Nominal dents on the metal casing are acceptable but there must not be any damage to the Control Panel and/or connection plate.
3. Examine the intended site of installation of the PropSava and ensure that the site has:
 - a) No water leakage, steam, oil-based dust and metal particles.
 - b) No corrosive, flammable, explosive liquid or gas.
 - c) Good ventilation.
 - d) Altitude: ≤ 2000 meters
 - e) Humidity: 0~95% (Not freezing point)
 - f) Ambient temperature: -15 - 40C
 - g) Has a clearance of 100mm above and 50mm on all sides of any surface
 - h) Has sufficient space to carry out a safe installation and maintenance.
4. Be sure to turn off the power before installing or servicing any PropSava to protect you and the PropSava.
5. Always isolate incoming power to the PropSava prior to removing the casing.
6. Please ensure that the PowaSava mains breaker switch is in the OFF position prior to connection of the Input and Output connections.
7. The PropSava Input side must be connected to the output side of the Electric meter using the appropriate rated size cables and must be earthed in the manner prescribed by local codes. Please see wiring diagram.
8. The PropSava Output side must be connected to the feed side of the Fuse/Consumer Board using the appropriate rated size cables and must be earthed in the manner prescribed by local codes. Please see wiring diagram.
9. Please keep connections runs to a minimum length; but allow enough cable to permit the inspection/maintenance of the PropSava.

Installation:

1. Preparing the PropSava for Installation:

- Unscrew the rear panel and place to one side. Check that there are 3 brass cable eyes attached to the Input Connector and 2 brass cable eyes connected to the Output Connector block.
- Switch Master Switch/RCB of the PropSava to off position.
- Use a multimeter or megohmmeter to check resistance between Input and Output terminals of PropSava to earth and ensure that it is more than 2Mohm. If not, then check environmental Humidity conditions; check for dirty contacts, dampness around the terminal block and rectify prior to installation.

2. Please follow all local codes on cable sizes, however, we recommend the minimum sizes for the Input/output cable as shown below:

Load (KVA)	Input voltage	Output voltage	Maximum Current	Input/output phase cable	Ground cable
5KVA	220V \pm 15%	220/210 \pm 1%	27 A	6 mm ₂	6 mm ₂
12KVA	220V \pm 15%	220/210 \pm 1%	65 A	16 mm ₂	6 mm ₂
18KVA	220V \pm 15%	220/210 \pm 1%	96 A	25 mm ₂	10 mm ₂
23KVA	220V \pm 15%	220/210 \pm 1%	123A	25 mm ₂	10 mm ₂

- Identify all lengths of cable runs required and connect the Input and Output cable eyes to your cables. Then connect the cables to the correct Input and Output cable block using the cable eye screws provided. Please tighten the cable eyes screws.
- Switch off the Master Switch at the Fuse/Consumer Board and remove existing input power cables and replace with the new PropSava Output cables.
- Remove the output cable from the electric meter and replace with the Input cables of the PropSava.

Wiring Diagrams:

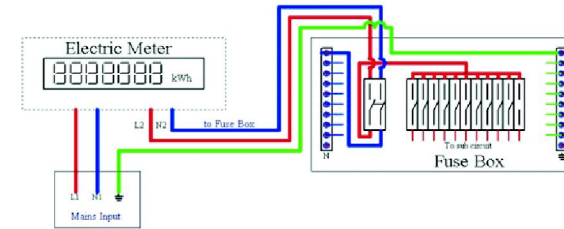

Existing Wiring Connection from Electric Meter to Fuse/Consumer Board

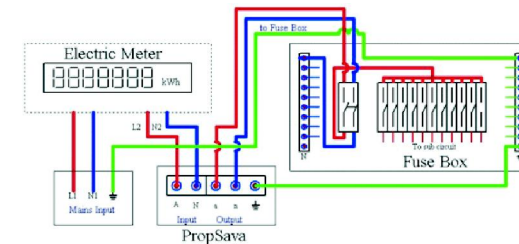

PropSava installed between the Electric Meter and Fuse/Consumer Board

Power On Test:

- Switch OFF the Master Switch of Fuse/Consumer box and then switch ON the Master Switch of PropSava.
- Check the PropSava display panel that it is showing the correct regulated Output voltage 220V \pm 1%.
- Press the NORMAL SAVING/OPTIMUM SAVING key, the voltage should now change to regulated Output voltage of 210V \pm 1% and the Optimal LED indicator will light.
- Press the ON/BY-PASS key and check that the PropSava goes into BY-PASS mode. When operating correctly the display will show the original incoming mains voltage directly from the electric meter and the BY-PASS LED will light.
- To restart the PropSava you must now switch off the PropSava Master Switch and then switch back on again.
- The panel voltage should now be showing the NORMAL regulated voltage of 220V \pm 1%.

Normal Power On:

1. Ensure that the Fuse/Consumer Board Master Switch is OFF
2. Switch on the Master Switch of PropSava.
3. Press the NORMAL SAVING/OPTIMUM SAVING key; set the Output regulated voltage to either 220V (NORMAL) or 210V (OPTIMAL).
4. Switch on the Master Switch to the Fuse/Consumer Board.

Service and Maintenance:

The PropSava has no parts that need regular servicing and/or maintenance. However we recommend that annual checks for safety and performance are carried out by a qualified electrician. As an absolute minimum, we recommend that every 10 (ten) years of service the Control Board be inspected and tested for safety and/or performance.

Working Principle:

1. Compensation unit consists of a compensating transformer, regulation transformer and contactless switches.
2. Sampling circuit consists of input voltage/current sampling, output voltage/current sampling.
3. Master control board consists of CPU, A/D converter, photo coupler etc.
4. Display/control panel consists of LED display and interface Ics.

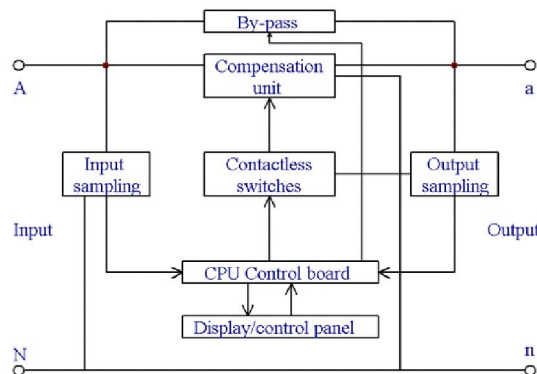

Display Panel:

The Display Panel shows the output voltage and output power of the load expressed as KW/H. The User can change the output voltage by pressing the NORMAL SAVING /OPTIMUM SAVING key. Pressing the ON/BY-PASS key immediately by-passes the incoming power from the electric meter directly to the Fuse/Consumer Board. The By-Pass system also operates automatically when the System identifies a fault.

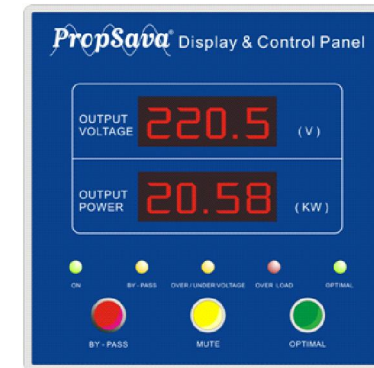

PropSava Type:

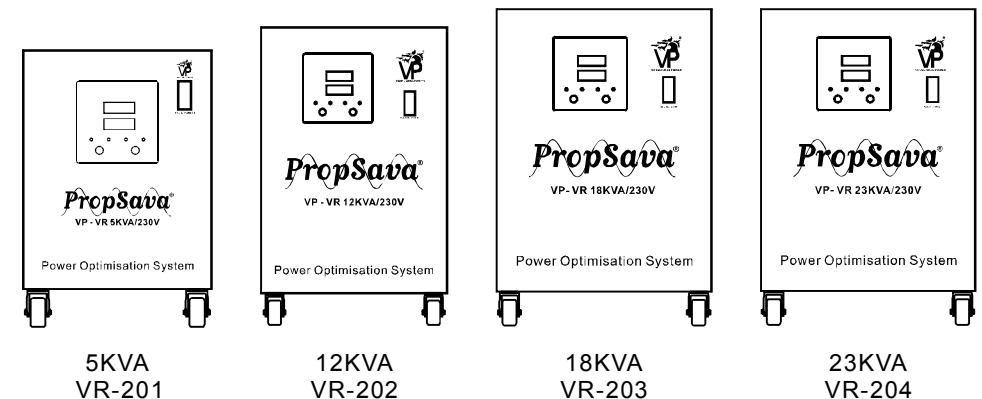

Specifications:

PropSava Type:	VR-201	VR-202	VR-203	VR-204	
Capacity:	5KVA	12KVA	18KVA	23KVA	
Input voltage for all models:	220V ±15% 50Hz				
Output voltage for all models:	Normal mode: 220V ±1% Optimal mode: 210V ±1%				
Output Maximum Current:	27A	65A	96A	123A	
Efficiency:	≥98%				
Response time:	≤40ms				
Output wave:	Additional Waveform deformation less than 0.4%.				
Protection:	Over voltage:	If output voltage is above 250V for 3 seconds the system will activate automatic by-pass. In by-pass state, if output voltage exceeds 250V for 3 seconds, then system will automatically shut down.			
	Under voltage:	If output voltage is under 180V for 3 seconds the system will automatically enter by-pass state. In by-pass state, if output voltage falls under 180V, after 3 seconds, then system will automatically shut down.			
	Over load:	If output current exceeds 100% of maximum rated current for 20 seconds, then system will automatically enter by-pass state. In by-pass state, if output current exceeds 100% of maximum rated current for 2 minutes, then system will automatically shut down.			
	Surge Protection:	IEC class II surge protection. Nominal discharge surge current is 20KA.			
	By-pass:	Automatic/Manual			
EMC and Safety	EMC:	EN61000-6-1, EN61000-6-3, EN61000-3-2, EN61000-3-3			
	LVD:	EN61558-2-12			
Life cycle:	Designed for 10 years minimum, up to 25 years subject to 10 year service intervals.				
Others:	Display:	Digital meter shows output voltage and power			
	Mute:	When buzzer is activated the mute button may be used to silence the noise.			
	Cooling:	Temperature controlled, low noise, long life Fan			
	Working temperature:	≤65C			
	Ambient temperature	-15 - 40C			
	Humidity	0~95% (Not freezing point)			
Physical:	Dimensions:	300(H) x450(W) x450mm (D)	350(H) x500(W) x520mm (D)	380(H) x600(W) x570mm (D)	380(H) x600(W) x570mm (D)
	Weight:	42KG	55KG	78KG	103KG
	Enclosure:	IP22			
	Feet:	4 wheels			

Surge Protection System:

Overview:

All PropSava single and 3 Phase Power Optimisation Systems have a surge arrester fitted as standard. This is not a luxury but an absolute necessity to protect not only the PropSava but also the entire site/properties electrical equipment. Surges are short-duration peak voltages i.e. transient voltages existing for only milliseconds; but can measure thousands of volts.

These surges are caused by:

1. Direct lightning strikes
2. Indirect lightning strikes within a distance of some kilometres
3. Switching operations in the power supply system
4. Faults due to switching operations within the installation

In the commercial sector, lightning or power surges cause 45% of electrical equipment damage. Overall, 28 out of 100 cases of damage to electronic equipment are caused by surges. Surges are by far the most frequent cause of damage and that is why surge arrestors are fitted as standard.

PropSava-Single Phase Standard Surge Arrester installed V 20-C/1+NPE-280 technical data:
Note: alternatives such as ABB, DEHN, PHOENIX, Schneider maybe used without notice.

Surge Controller surge arrester Description:	V 20-C/1+NPE-280
Maximum continuous operating voltage Uc:	280 V~
LPZ:	1 → 2
Requirement class to VDE 0675, Part 6 (Draft 11.89):	C
A1, A2 to IEC 61643-1:	Class II
Tested to:	IEC 61643-1, pr EN 61643-1, E DIN VDE 0675-6:1989-11 and Part 6/A1
Nominal discharge current of the upper part In (8/20):	20KA
Maximum discharge current of the upper partImax (8/20):	50 kA
Voltage protection level	
at 1 kA (8/20) Up:	≤1.2 KV
at 5 kA (8/20) Up:	≤1.5 KV
at In Up:	≤1.8 KV
Response time Ta:	<25 ns
Short-circuit withstand strength 25 kA with max. upstream fuse:	125 A gL/gG
Connection cross-section:	2.5-35 mm2 (single and multi stranded) 2.5-25 mm2 (fine-stranded with core end sleeves)
;Mounting:	Snap-fitting on 35 mm top-hat rail to DIN EN 50022
IP Code:	IP20
Temperature range:	-40 °C to +80 °C

PropSava-Single Phase Optional Surge Arrester type V 25-B+C/1+NPE-280 technical data:
Note: alternatives such as ABB, DEHN, PHOENIX, Schneider maybe used without notice.

Surge Controller surge arrester Description:	V 25-B+C/1+NPE-280
Maximum continuous operating voltage Uc:	280 V~
LPZ:	0 → 2
Requirement class to VDE 0675, Part 6 (Draft 11.89):	B+C
A1, A2 to IEC 61643-1:	Class I+II
Tested to:	IEC 61643-1, pr EN 61643-1, E DIN VDE 0675-6:1989-11 and Part 6/A1
Nominal discharge current of the upper part In (8/20):	30KA
Maximum discharge current of the upper part I _{max} (8/20):	50 kA
Voltage protection level	
at 1 kA (8/20) Up:	≤0.9 KV
at 5 kA (8/20) Up:	≤1.2 KV
at In Up:	≤1.5 KV
Response time Ta:	<25 ns
Short-circuit withstand strength 25 kA with max. upstream fuse:	160 AgL/gG
Connection cross-section:	2.5-35 mm ² (single and multi stranded) 2.5-25 mm ² (fine-stranded with core end sleeves)
;Mounting:	Snap-fitting on 35 mm top-hat rail to DIN EN 50022
IP Code:	IP20
Temperature range:	-40 °C to +80 °C

PropSava Fault Finding and Recommendations for Electricians ONLY:

NOTE: In the unlikely event of any fault developing on the PropSava, the automated By-Pass system will be engaged and the electrical power from the mains supply will be diverted DIRECTLY to the Fuse/Consumer Board. The User of the PropSava may be able to restart the PropSava by turning the Master Switch of the PropSava Off then On. If this does not restart the PropSava where you see the Output Voltage and Output Power reading and the Main LED illuminated please call your service centre and/or the installing Electrician.

WARNING:

DO NOT ATTEMPT, UNDER ANY CIRCUMSTANCES, TO REMOVE ANY WIRES AND/OR PANELS OF THE PROPSAVA. ALL THE CONTROLS OF THE PROPSAVA ARE EXTERNAL THAT CAN BE OPERATED BY THE USER. ALL OTHER EXAMINATION OR WORK MUST BE CARRIED OUT BY A QUALIFIED ELECTRICIAN. FAILURE TO OBSERVE THIS WARNING MAY RESULT IN SERIOUS INJURY FROM ELECTROCUTION AND MAY BE FATAL.

Fault Description:	Reason:	Recommendations:
Shut Down	1.No power 2.Input power out of range	Check the input cable and voltage
Does not operate	1.Input power out of range 2. Over load 3.Fuse break	1.Check input voltage. 2.Check the load for short circuit or over load. 3.Check out and change it.
Output Voltage out of range	Input power out of range	Check input voltage.

Declaration of Conformity:

The Manufacturer of the Products covered by this Declaration is:

Vanguards Power (Hong Kong) Limited
 1508 Eastern Tower, Yihai Square,
 Commercial Building
 North Chuang Ye Road, Nanshan, Shenzhen.518054, China

Company Registered in Hong Kong Number: 1125122

The Directives covered by this Declaration:

Council Directive 89/336/EEC and LVD Directive 73/23/EEC, including amendment 2004/108/EC and 2006/95/EC-Council Directive Amending Directives
 The Product Covered by this Declaration is the PropSava® 230V, 23KVA, 18KVA, 12KVA and 5KVA Power Optimisation System.

The Basis on which Conformity is being declared:

EMC Test Standards: EN61000-6-1:2007; EN61000-6-3:2007; EN61000-3-2:2006;
 EN61000-3-3:1995+A1:2001+A2:2005.
 LVD Test Standards : EN61558-2-12:2002.

The manufacturer hereby declares under his sole responsibility that the products identified above comply with the protection requirements of the EMC directive and with the principal elements of the safety objectives, and that the standards have been applied.

The technical documentation required to demonstrate that the products meet the above requirements has been compiled and is available for inspection by the relevant enforcement authorities. The CE mark was first applied in September 2009.

Warranty Terms & Conditions:

1. These Terms and Conditions do not affect your statutory rights.
2. Please check the PropSava package and contents as soon as possible. If the PropSava or any other item included in the package is damaged or faulty, you must inform your supplier immediately or at the latest within 7 (seven) days of the date of purchase. If the supplier you purchased it from does not offer an exchange and/or replacement service, we will arrange collection and replacement at our cost. If you do not inform us within 7 days we shall have no liability for the PropSava said to be damaged and/or items missing at time of purchase.
3. Vanguards Power (Hong Kong) Limited, hereafter referred to as "VPHK" guarantee that the PropSava will be free from defects for 10 (ten) years from the date of purchase, subject to completion, supplier stamping and the registering with VPHK of the attached Warranty Card. If no Warranty Card is registered with VPHK within 3 months of the date of installation, the PropSava will be warranted for 1 year from date of installation. If PropSava does not conform to this Warranty then we will at our option either remedy the defect in question or replace the PropSava, or refund the price paid, subject to sight of the original receipt from the supplier where it was purchased.
4. Subject to registration of the completed and supplier stamped Warranty Card, the first 10 (ten) years of Warranty covers parts and labour. The warranty period commences on the day of successful installation by a qualified electrical Engineer. Any repairs or parts supplied or other work carried out which are found to be outside the terms of this warranty will be charged to the purchaser, and will be payable at the point of service. If no fault is found or the fault is outside the scope of the warranty then a possible charge for labour and transportation may also be made.
5. The purchaser must ensure the environmental and power supply conditions are suitable for the PropSava and that the PropSava is cared for and maintained in accordance with the recommendations stated in this User manual.
6. To return goods please contact your Supplier .

Exclusions to the Warranty:

7. Breakdowns or failures arising from any external influences such as misuse, neglect, accidental damage, inadequate ventilation/temperature control of the area of installation, harmonic wave distortion, power factor below 0.8, transients of any kind above the surge rated protection, short circuits, loading to the PropSava above the original specification of build, any unauthorised tampering with the system and/or its software, and other external influences such as, but not limited to poor environmental conditions.
8. Purchaser's consequential loss or liability of any kind.
9. We do not accept liability for returns damaged in transit or not received by us.
10. Every care has been taken in the preparation of all and any details or statement made in this User Manual and the PropSava® packaging. However, as far as is permitted by applicable law, we disclaim all warranties, express or implied as to the accuracy of information contained herein.

Warranty Card: Please complete all sections, detach and mail to your Distributor

KVA Size: _____ Voltage Rating: _____ Serial Number: _____

Date of Installation: _____ Installer/Engineer Name: _____

Installer/Engineer Company Name: _____

Installer/Engineer address: _____

_____ Country: _____

Installer/Engineer Statement: I confirm that the above stated PropSava has been installed in accordance with current building and electrical code(s) of safety and conditions specified in the User Manual for such products.

Signed: _____ Dated: _____

Name of Customer or Company: _____

Name of Contact: _____ Telephone (Incl. Country code): _____

Address of installation: _____

_____ Country: _____

Distributor Name: _____

Distributor Stamp:



Dated: _____ Signed on behalf of authorised Distributor: _____